

High Pressure Centrifugal Slurry Pump / Submerged Vertical Sewage Pump

Our Product Introduction

Basic Information

- Place of Origin: Sichuan, China
- Brand Name: horizontal-slurrypump.com
- Certification: ISO9001
- Model Number: OEM
- Minimum Order Quantity: 1 set
- Price: USD 500-5000/set
- Packaging Details: Free Fumigation Export Wooden Box
- Delivery Time: 25 working days after receiveing advance payment
- Payment Terms: L/C, D/A, D/P, T/T, Western Union, MoneyGram, Paypal
- Supply Ability: 300 sets per month



Product Specification

- Theory: Centrifugal Pump
- Max Flow: 364m³/ H
- Max Head: 58m
- Material: Corrosive Resistance Material
- Fuel: Electric
- Color: Customized
- Voltage: 380V/660V/1140V
- Structure: Single-stage Pump
- Product Name: Submersible Sewage Sump Mud Pump
Submerged Slurry Pump
- Highlight: **vertical sewage pump**

for more products please visit us on horizontal-slurrypump.com

Product Description

High Pressure Centrifugal Slurry Pump , Submerged Vertical Sewage Pump

Product Description

ZJL-series vertical slurry pumps are single stage single-suction centrifugal slurry pump. ZJL-series pumps are in accordance with theory of two-phase fluids and they are designed according to the principle of minimizing the total loss. Geometrical shape of its flow passage components is suitable for flow condition of medium. In this way, the hydraulic loss among parts where eddy and impacting occur is reduced so that abrasion of flow passage components is reduced; water efficiency is increased; running noises and vibration are reduced. High-chrome alloy, which has high wear resistance, corrosion resistance and impact resistance, is used for flow passage components to improve service life.

Main Usage

· Mining
· Civil Construction
· Industry
· Coal Preperation
· Mineral Processing
· Chemical Preccessing



Product Features

- 1 Flow passage components: this type of pump use wear resistant metal, impeller choose wear resistant metal or rubber.
- 2 Bearing components: we use grease lubrication. According to slag slurry pool liquid height, can choose different lengths of pump shaft or suction pipe.
- 3 Sealing: Doesn't need any shaft seal or shaft seal water. In suction volume insufficient condition also can work normally below.

Technical Parameter

Model	Clear Water Performance					Supporting motor
	Rotating speed n	Flow Q	Head H	Shaft power Pa	effectiveness η	
	r/min	(m ³ /h)	m	kw	%	
980	198	17.9	15.3	63.1	Y250M-6 V1 380V 37kw	
	332	13.2	17.5	68.1		
	364	12.1	18.0	66.8		
730	147	10.0	6.3	63.1	Y200L-8 V1 380V 15kw	
	247	7.3	7.2	68.1		
	271	6.7	7.4	66.8		

150ZJL-A35	590	119	6.5	3.3	63.1	Y160L-10 V1 380V 11kw
		200	4.8	3.8	68.1	
		219	4.4	3.9	66.8	
100ZJL-A36	1480	113	51.1	32.1	54.1	Y250M-4 V1 380V 55kw
		185	42.2	39.4	58.9	
		239	34.1	45.1	54.2	
	970	76	22.9	9.6	54.1	Y200L1-6 V1 380V 18.5kw
		124	18.9	11.8	58.9	
		160	15.3	13.5	54.2	
80ZJL-A33	1480	100	46.8	26.8	52.6	Y225M-4 V1 380V 45kw
		141	41.6	31.0	56.5	
		157	36.5	33.2	52.3	
	970	42	16.8	5.5	52.6	Y180L-6 V1 380V 15kw
		94	12.4	7.1	56.5	
		122	8.4	8.7	52.3	
65ZJL-A38	1470	75	52.3	23.1	42.7	Y225S-4 V1 380V 37kw
		97	45.8	26.4	45.8	
		120	43.4	28.8	45.6	
	970	50	23.4	6.9	42.7	Y180L-6 V1 380V 15kw
		65	20.5	7.9	45.8	
		80	19.4	8.6	45.6	
65ZJL-A30	1470	38	34.7	8.2	43.7	Y180M-4 V1 380V 18.5kw
		58	31.9	9.7	51.9	
		98	26.0	13.4	51.7	
	960	25	14.8	2.3	43.7	Y132M2-6 V1 380V 5.5kw
		38	13.6	2.7	51.9	
		64	11.1	3.7	51.7	
50ZJL-A40	1470	31	58.3	16.5	29.9	Y200L-4 V1 380V 30kw
		47	51	19.1	34.1	
		65	37.9	22.1	30.3	
	970	21	25.4	4.9	29.9	Y160L-6 V1 380V 11kw
		31	22.2	5.5	34.1	
		43	16.5	6.4	30.3	
50ZJL-A36	1470	36	42.7	15.7	31.2	Y200L-4 V1 380V 30kw
		63	37.8	18.7	39.4	
		85	29.3	20.7	33.5	
	970	24	19.1	4.7	31.2	Y160L-6 V1 380V 11kw
		42	16.9	5.6	39.4	
		57	13.1	6.2	33.5	
50ZJL-A20	1440	17.1	10.7	1.4	34.9	Y112M-4 V1 380V 4kw
		24.7	9.2	1.6	38.6	
		38.0	6.0	2.0	31.2	
	910	10.8	4.3	0.4	34.9	Y90L-6 V1 380V 1.1kw
		15.6	3.7	0.4	38.6	
		24.0	2.4	0.5	31.2	
40ZJL-A35	1470	23.7	42.9	12.8	27.3	Y180L-4 V1 380V 22kw
		42.3	34.3	13.7	33.8	
		47.6	30.5	14.1	28.1	
	970	15.8	19.2	3.8	27.3	Y160M-6 V1 380V 7.5kw
		28.3	15.3	4.1	33.8	
		31.8	13.6	4.2	28.1	
40ZJL-A25	1440	10.1	21.5	2.3	26.1	Y132S-4 V1 380V 5.5kw
		18.4	19.0	2.6	36.6	
		22.9	16.8	2.8	37.6	
	910	6.6	9.2	0.6	26.1	Y90L-6 V1 380V 1.1kw
		12	8.1	0.7	36.6	
		14.9	7.2	0.7	37.6	
40ZJL-A21	1440	9.5	17.0	1.6	27.9	Y112M-4 V1 380V 4.0kw
		20.3	15.3	2.0	42.4	
		25.9	14.1	2.2	44.6	
	910	6.0	6.8	0.4	27.9	Y90L-6 V1 380V 1.1kw
		12.8	6.1	0.5	42.4	
		16.4	5.6	0.6	44.6	

Structure

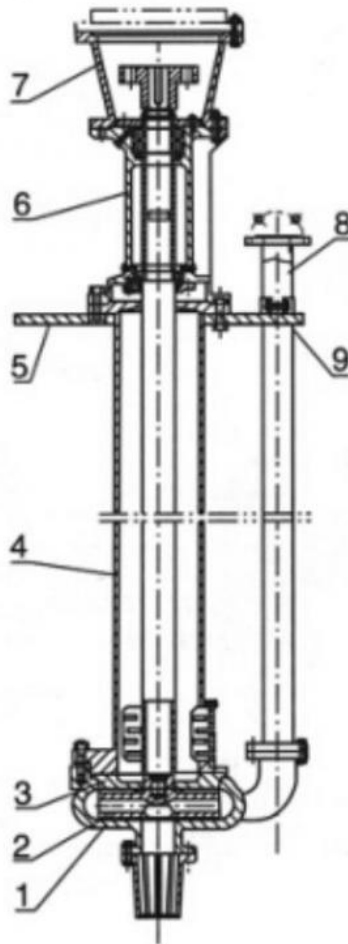

1	Volute casing	2	support	3	Motor base
4	Impeller	5	Left support plate	6	Discharge pipe
7	Rear liner plate	8	Bearing body	9	Right support plate

Product Picture





Installation Dimension

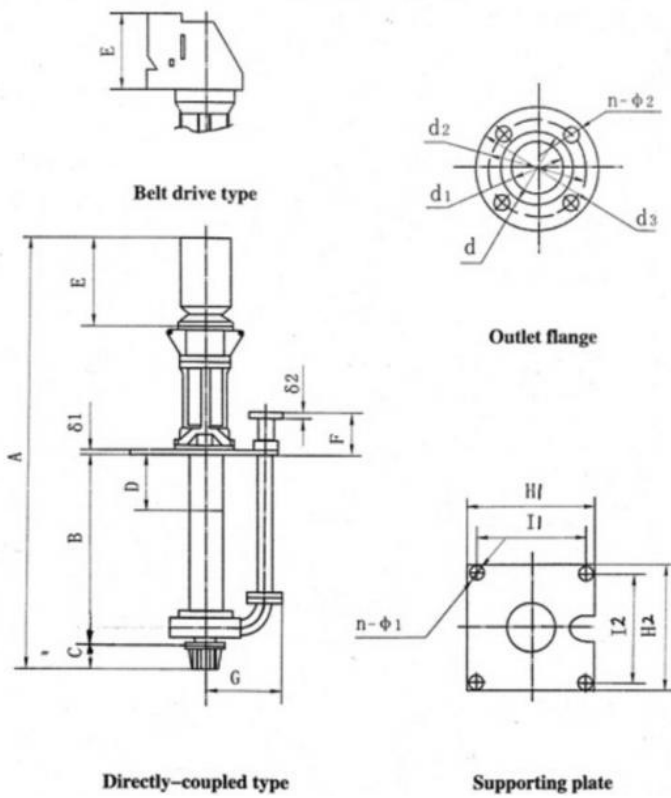

ROMAN Beijing Silk Road Enterprise Management Services Co.,LTD

☎ 0086-17773109286 ✉ jeffreyth@slurrypump.com 🌐 horizontal-slurrypump.com

Floor 5, 2nd Building, Zhonglu Industrial Zone, Shenzhen City, Guangdong Province China (Mainland)