

## Vertical Submerged Centrifugal Pump , Sustainable Single Stage Centrifugal Pump

Our Product Introduction

### Basic Information

- Place of Origin: Sichuan, China
- Brand Name: horizontal-slurrypump.com
- Certification: ISO9001
- Model Number: OEM
- Minimum Order Quantity: 1 set
- Price: USD 500-5000/set
- Packaging Details: free fumigation export wooden box packaging
- Delivery Time: 25 working days after receiveing advance payment
- Payment Terms: L/C, D/A, D/P, T/T, Western Union, MoneyGram, Paypal
- Supply Ability: 300 sets per month



### Product Specification

- Max Flow: 450m3/h
- Max Head: 120m
- Temperature: -50-80°C
- Voltage: Requirements
- Warranty: 1 Year
- Power: 5.5-160KW
- Color: Customized
- Brand Name: Chengdu Yongyi
- OEM: Welcome
- Highlight: **vertical chemical pump**



for more products please visit us on [horizontal-slurrypump.com](http://horizontal-slurrypump.com)

## Product Description

### Vertical Single-stage Circulating Centrifugal Pump, Sustainable Corrosive Resistant Pump

#### Product Description

WDL-series pump is anti-abrasive and anti-corrosive vertical submerged centrifugal pump, which is designed according to multiphase flow theory and practice experience. WDL-series single stage single-suction pump is applicable to convey easy crystal medium containing solid particles, featured by excellent performance, advanced structure, good anti-cavitation properties, strong bearing, stable operation, easy maintenance and long service life.

#### Technical Parameter

model	flow (m <sup>3</sup> /h)	Head (m)	Rotating speed (r/min)	Highest efficiency (%)	pump head weight KG	Submerged depth mm	Shaft component
40WDL-250	8-20	15-28	1450	39	620	1300/1000	100
40WDL-310	8-40	23-42	1450	45	692	1300/1000	100
40WDL-350	8-45	35-54	1450	37	870	1300/1000	120
50WDL-250	10-30	15-28	1450	40	642	1300/1000	100
50WDL-310	15-60	25-42	1450	45	705	1300/1000	100
50WDL-350	15-70	35-54	1450	50	886	1300/1000	120
50WDL-400	20-75	50-75	1450	45	961	1300/1000	120
65WDL-250	30-70	15-28	1450	48	652	1300/1000	100
65WDL-310	30-90	25-40	1450	57	905	1300/1000	120
65WDL-350	40-100	35-54	1450	59	915	1300/1000	120
65WDL-400	50-120	45-75	1450	55	1008	1300/1000	120
65WDL-450	50-120	70-95	1450	52	1075	1300/1000	120
80WDL-250	70-100	15-25	1450	61	652	1300/1000	100
80WDL-310	70-120	25-40	1450	62	935	1300/1000	120
80WDL-350	70-160	35-52	1450	65	940	1300/1000	120
80WDL-400	70-160	50-75	1450	62	1068	1300/1000	120
80WDL-450	70-160	70-95	1450	60	1100	1300/1000	120
100WDL-310	100-150	20-38	1450	65	960	1300/1000	120
100WDL-350	100-220	35-50	1450	65	970	1300/1000	120
100WDL-400	100-220	40-72	1450	65	1125	1300/1000	120
125WDL-310	120-260	18-36	1450	67	1025	1300/1000	120
125WDL-350	120-300	35-50	1450	68	1035	1300/1000	120
125WDL-400	140-350	45-70	1450	70	1206	1300/1000	120
125WDL-450	150-360	65-90	1450	67	1497	1300/1000	140
150WDL-310	200-400	18-35	1450	72	1127	1300/1000	120
150WDL-350	200-450	25-48	1450	75	1175	1300/1000	120
150WDL-400	200-450	40-65	1450	73	1668	1300/1000	140

#### Application

In the fields of chemical industry, metallurgy, power industry, paper making industry, food industry, pharmaceutical industry and synthetic fibre industry, WDL-series pumps are applicable to convey corrosive and abrasive liquid (solid content is no more than 40% ).

#### Product Picture

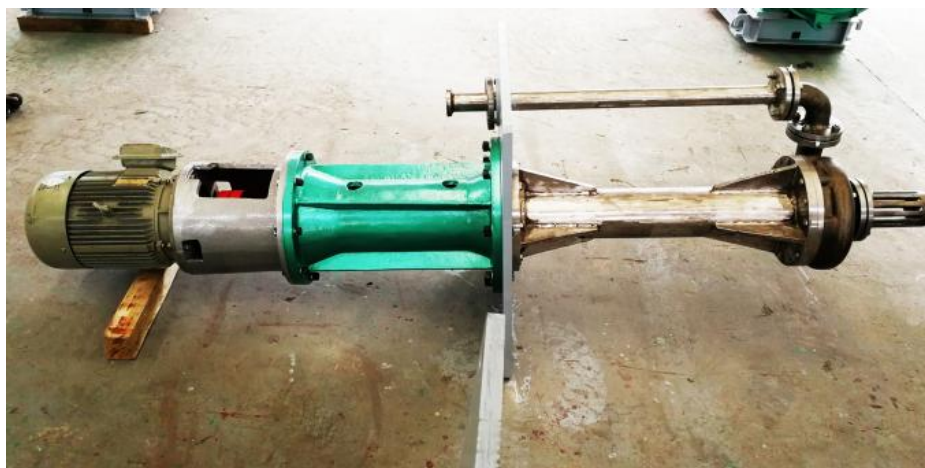

#### Installation Dimension

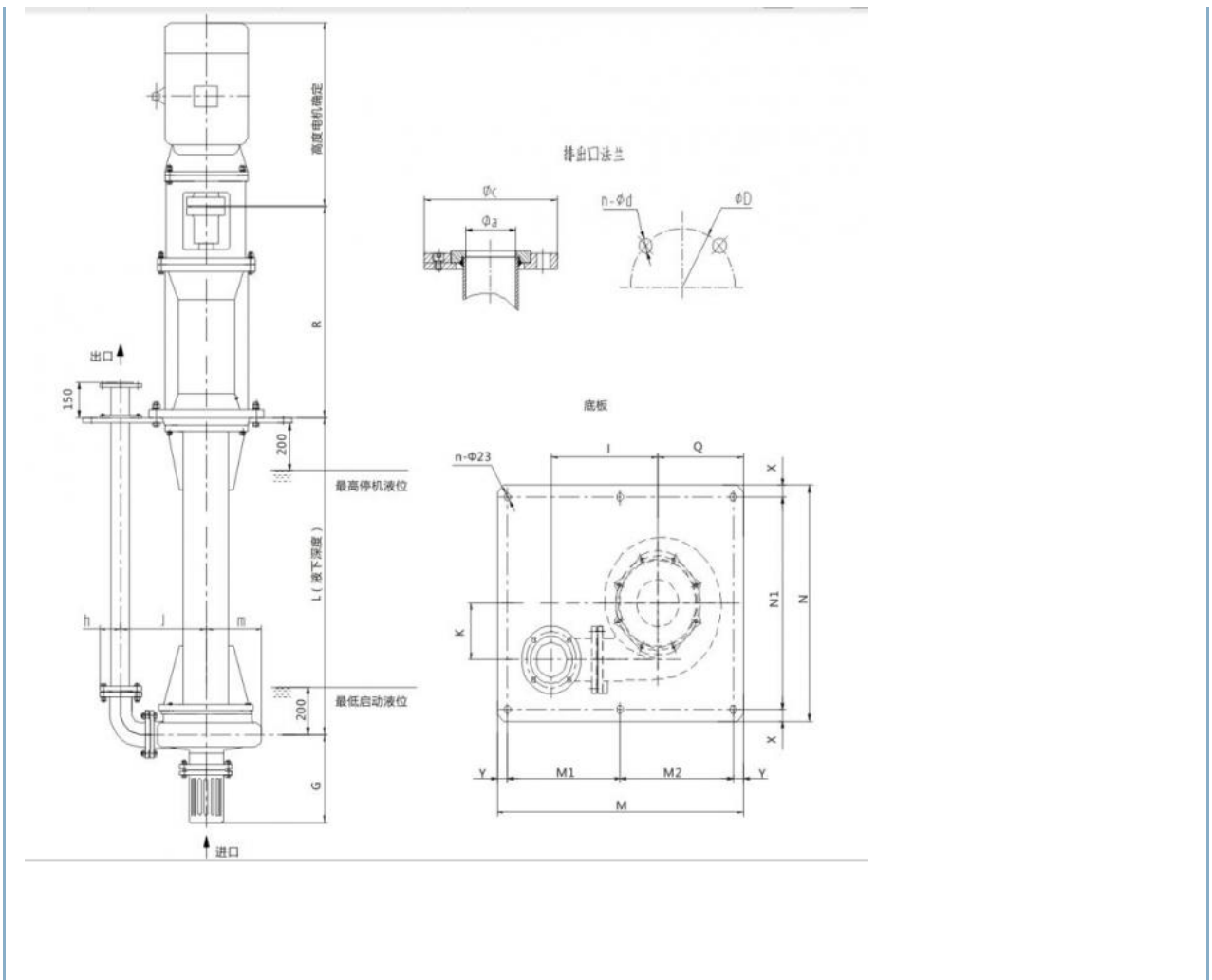

**ROMAN** Beijing Silk Road Enterprise Management Services Co.,LTD

☎ 0086-17773109286

✉ jeffreyth@slurrypump.com

🌐 horizontal-slurrypump.com

Floor 5, 2nd Building, Zhonglu Industrial Zone, Shenzhen City, Guangdong Province China (Mainland)